

Paper presented at the Conference on

Clusters, Industrial Districts and Firms:
the Challenge of Globalization.

Conference in honour of Professor Sebastiano Brusco

Modena, Italy. September 12-13, 2003

TAIWAN'S HSINCHU REGION: IMITATOR AND PARTNER FOR SILICON VALLEY

AnnaLee Saxenian

University of California at Berkeley
anno@socrates.berkeley.edu

May, 17th 2002

Thanks to Wendy Li for first-rate research assistance. Please do not circulate or cite without permission.

The global electronics industry was badly shaken when a 7.3 Richter scale earthquake hit Taiwan in September 1999. In Silicon Valley, the center of technology and product innovation for the industry there was widespread concern about lengthy interruptions in the supply of computers, semiconductors, and other key components. The concern was well founded: Taiwanese companies produce the majority of the world's notebook computers, motherboards, monitors, optical scanners, power supplies, and a range of other electronics-related products. In addition, the island's semiconductor foundries account for two-thirds of global foundry output. *See Figures 1 & 2.*

The impact of the earthquake was quite limited as most Taiwanese manufacturers returned quickly to pre-quake production levels. However the earthquake scare revealed the importance of this small island to the global information technology (IT) industry. As late as 1980, Taiwan served primarily as a source of low-cost labor for foreign consumer electronics corporations. In the following decades, indigenous producers of personal computers (PCs) and integrated circuits (ICs) emerged as key players in international production networks. By 1999 Taiwan ranked as the world's third largest producer of IT hardware, following only the US and Japan. *See Figures 3 & 4.*

Information technology production fuelled Taiwan's impressive economic growth in the last two decades. Taiwan's IT output grew from less than \$100M in 1980 to over \$5B in 1989 and grew over 20% annually in the 1990s (when GDP growth hovered around 6-7%) to reach \$21B in 1999.¹ High technology exports, which now account for close to half of the island's total exports, thus were the main force driving a more than doubling of the GNP per capita income in just over a decade--from \$6,333 in 1988 to \$13,235 in 1999 (Taipei: MOEA, Monthly Bulletin of Statistics, Dec 2000, National Economic Trends.)

How did this small, and until recently very poor, island of 24 million surpass other Asian economies as well as more advanced economies in the global technology competition? While Taiwan's initial advantage was its low cost labor, it is now recognized as a global center of electronic systems design, manufacturing, and logistics. Many observers claim that today Taiwan's manufacturing expertise has no parallel, even in the US. One indicator of Taiwan's technological achievements is its rapid mobility in international rankings of U.S. patent recipients: in 1980, Taiwan ranked 21, by 1990 it had reached 11, and in 1995 Taiwan ranked 7 (Taiwan National Science Council, 1995.) Today Taiwan receives substantially more patents per capita than the other Asian NICs (South Korea, Singapore, and Hong Kong) and, along with Israel, ranks ahead of all of the G7 except the U.S. and Japan. (Trajtenberg, 1999.) *See Figure 5.*

The dominant accounts of the Taiwanese postwar economic 'miracle' focus on the state's role in directing development in traditional industries such as chemicals, textiles, and electrical machinery (Wade, 1990.) Scholars attribute Taiwan's more recent successes in IT-related industries to activist government policy as well, focusing on the institutions of a 'developmental' state, such as the publicly funded research and development (R&D) agency, Industrial Technology and Research Institute, ITRI (Mathews, 1997.) This approach assimilates Taiwan's IT growth in the 1990s to that of Japan and Korea in the 1980s, overlooking how fundamental differences in the relationship between the state and the organization of production have shaped industrial performance.

This paper argues that although the state played a very important role in the early development of Taiwan's IT sector, the region has more in common with Silicon Valley, Israel, and even with the

¹ If Taiwanese manufacturing in China is included, 1999 IT output was over \$35B.

nascent IT industries India and Ireland, than with the other East Asian NICs. The dynamism of Taiwan's IT industries, like those of Silicon Valley and its other 'imitators,' is rooted in the incremental deepening and broadening of the capabilities of a localized cluster of specialist producers as well as in its close economic ties to the original Silicon Valley. This differs fundamentally from the privileged relationship between the state and a handful of large, established corporate giants that characterized IT development in Japan and Korea in the 1980s. If the East Asian case is viewed as state-led development, then the experience of Silicon Valley, Taiwan, and its other 'imitators' is best understood as entrepreneurship-led growth.²

Taiwan's IT sector is dominated today by indigenous firms, most of which were started in the past two decades. While Japanese and American electronics companies helped to develop a skill base and infrastructure in the 1960s and 1970s, and while foreign companies still have a presence in the industry, the central dynamic in the cluster's growth and upgrading has been provided by Taiwanese entrepreneurs and firms. The majority of these firms remain small by global standards, however some have grown to dominate important segments of world markets. Even as they grow large, however, they continue to collaborate (as well as compete) with other local specialists in a way that is reminiscent of the Silicon Valley economy.

The following section of this essay examines the factors underlying the initial emergence of Taiwan's IT sector in the early 1980s: FDI and public investments in education and research capabilities initially, and later, policies to develop and transfer technology to the private sector and to support new industrial entrants, combined with growing ties to the Overseas Chinese community in Silicon Valley.

The third section provides an overview of the organization of production in the Taiwan's IT sector today and examines the historical evolution of the PC and IC industries since 1980. The fourth section explores how industrial decentralization and close ties to Silicon Valley contribute to the cluster's capacity for adaptation and innovation. A final section addresses the challenges that Taiwan faces to further industrial upgrading and speculates about its relationship to Mainland China.

The Emergence of Taiwan's IT Sector

The origins of an indigenous IT industry in Taiwan date to the emergence in the early 1980s of two separate clusters of entrepreneurship. Dozens of small firms and start-ups in the Taipei area began cloning PCs and components, building on the skills and infrastructure created by consumer electronics-related MNCs in earlier decades. At about the same time, a handful of IC manufacturing and design start-ups were spun-out of the government funded semiconductor research institute, the Electronics Research and Service Organization (ERSO) in the Hsinchu Science Park.

These two nascent clusters built on the infrastructure and skill base created by two decades of public investments in education, as well as by FDI from the US and Japan. A couple dozen multinationals located plants in Taiwan in the 1960s and 1970s to exploit its cheap low skilled workforce and the generous incentives of its export processing zone for manufacturing of labor

² An emphasis on entrepreneurship was explicit in Taiwanese policy from the beginning. The 1961-64 plan, for example, states that "It is true that Taiwan is short of capital, but what is wanted most is entrepreneurs and their entrepreneurship." (Wade, 1990: 88)

intensive consumer electronics such as TVs, VCRs, and calculators as well as for semiconductor packaging and testing. This era of FDI in electronics was critical to the development of the PC industry, in particular, because the MNCS had created a pool of manufacturing skill, basic management and marketing capabilities, and a local infrastructure of materials and parts suppliers.

A majority of Taiwan's political leaders in the 1960s and 1970s were technocrats with held graduate degrees in engineering-related fields from universities in the US or Japan. They had thus been exposed to the world's largest and fastest growing economies. Motivated by the desire to establish domestic economic strength--in large part to compensate for the island's political isolation--these policymakers developed programs and institutions to develop Taiwan's technological capabilities. They focused initially on improving the skill-base and technical infrastructure in what was still a very poor country: Taiwan's GNP per capita in 1962 was US \$170, on par with Zaire and the Congo (Wade, 1990.)

These policymakers began by making substantial investments in technical education and in upgrading the capabilities of public research institutions. The annual number of graduates of higher education grew from under 10,000 in 1961 to almost 200,000 in 1996--and 40% of these degrees were in engineering. *See Figure 6.* Taiwan's Ministry of Economic Affairs (MOEA) also established the Industrial Technology Research Institute (ITRI) in 1973 to provide joint research, technical services, and advice to Taiwan's SME's. One of its top priorities, based in part on advice from Overseas Chinese experts in the US, was the semiconductor industry. The following year ITRI officials created the Electronics Research and Service Organization (ERSO), a subsidiary devoted to research on semiconductor manufacturing and commercialization. By 1987 ERSO had a staff of over 1,700 and a budget of about US \$100 million (Wade, 1990.)

During this period Taiwan's policymakers also offered a variety of grants, low-interest loans, and subsidies to foreign and domestic electronics firms. While these programs undoubtedly contributed to the subsequent dynamism of the IT industry, it is worth underscoring that these incentives, like the investments in education and research, were universally available to all producers in a sector. Indeed, Taiwan's industrial policy systematically encouraged new market entry and the growth of small and medium-sized enterprises (Callon, 1995.) At a time when European and East Asian governments were channeling resources to large, established producers, or "national champions," Taiwan's policymakers created a more competitive environment by supporting multiple firms in any initiative, and constantly putting pressure on the established players.

To be sure, this strategy reflected the existing industrial structure of Taiwan, where the overwhelming majority of the manufacturers were very firms. However an equally important, and often overlooked factor influencing Taiwan's decision makers in this period was the policy advice from Overseas Chinese engineers. Taiwanese officials began traveling to Silicon Valley in the 1960s and 1970s, long before most of the world was aware of its existence. Senior economic ministers studied the Silicon Valley experience and institutionalized mechanisms for eliciting advice on technology and industrial policy from the region's community of US-educated Taiwanese engineers (Meany, 1994.) Many policies pursued in Taiwan in the 1970s and 1980s--including the emphasis in science-based industry, the rapid transfer of public research to the private sector, and the creation of a domestic venture capital industry--were influenced by the Silicon Valley model.

The boldest attempts to imitate Silicon Valley were the establishment of the Hsinchu Science-based Industrial Park and of a Taiwanese venture capital industry. The National Science Council (NSC)

sponsored the Hsinchu Science Park in 1980 to attract foreign and Overseas Chinese investments in research-oriented companies. The Park was located near two leading technical universities, National Chiaotung and Tsinghua, and ERSO labs were moved to the area as well. In addition to actively recruiting Taiwanese who were working abroad to return home, Government-owned banks offered to invest up to 49% of the shares in joint ventures, and the Park Administration provided generous tax incentives to qualified (research-intensive) firms, including a five-year tax holiday followed by a maximum tax rate of 22%.

The Ministry of Finance created the institutional framework for a Taiwanese venture capital industry in the early 1980s in order to provide funding for the research-intensive production they aspired to attract to the Science Park--and to promote the development of a public capital market. They consulted with investment professionals, organized collaborations with large US banks to transfer financial and managerial expertise, and sent teams to Silicon Valley to be trained in managing a venture capital firm. The government offered a 20% tax reduction to individual or corporate investors in venture capital funds that were targeted to strategic (technology-intensive) industries. However, faced with the challenge of raising capital from Taiwan's risk-averse financial and industrial communities, they also invited Overseas Chinese to establish venture firms in Taiwan. Two Silicon Valley venture capitalists thus established the second and third venture funds in Taiwan, after the initial government-sponsored Acer fund. (Saxenian and Li, 2000.)

While these policies created a fertile environment for the growth of the IT industry, Taiwan remained a low value added producer throughout the 1980s. It was not until the 1990s that local firms began to differentiate themselves on the basis of innovation and quality, rather than low cost labor. The shift is attributable in part to growing production experience and "learning by doing." But the most significant change was the "reversal" of the brain drain in the early 1990s, when thousands of Chinese engineers who had been educated and worked in the US returned to Taiwan either to start companies or work for start-ups or established companies. *See Figure 7.* These returnees, many of whom had worked for at least a decade in Silicon Valley, brought with them technical skill, organizational and managerial know-how, entrepreneurial experience, and connection to leading edge IT markets in the US.

While the Hsinchu Science Park attracted less than ten returnees a year in the early 1980s, more than 2,500 returnees began working in the Park during the 1990s, or some 350 per year. Not surprisingly, the returnees were over-represented in senior management ranks. In fact returnees were responsible for starting more than 40% of the 284 companies located in the Park in 1999. While data is not available, it is likely that still more returnees either started or worked for other IT-related companies in the Taipei area. As the returnee population in Hsinchu Science Park took off in the mid 1990s, so too did venture capital investments and the sales of companies in the Park, which had grown only slowly in the 1980s. *See Figures 8 & 9.* This suggests that returnees from Silicon Valley were at least as important, if not more so, than the Science Park or even the venture capital industry to the successful performance of Taiwan's IT sector in the 1990s.

The infusion of entrepreneurial and managerial resources from the US, as well as the connections they provided to technology and markets in Silicon Valley, were decisive in shifting Taiwan to the technological frontier in the manufacturing of ICs, PCs, and related components in the 1990s. By 1999 Taiwan was home to 153 venture capital firms that invested \$1.08B in IT-related businesses, making it, along with Israel, the largest in the world after Silicon Valley. And the Hsinchu Science Park was so crowded by the end of the 1990s that the Taiwanese government began plans to build another Park in Tainan, to the south.

The Hsinchu Industrial System Today

Taiwan's PC and IC industries are geographically clustered in a pattern that closely resembles that of Silicon Valley. The majority of the island's approximately 10,000 IC and PC-related firms are located within the 50-mile region linking the Taipei metropolitan area and the Hsinchu Science-based Industrial Park in the northwest of Taiwan--referred to hereafter as Hsinchu. This geographic separation from Taiwan's traditional industries to the south has facilitated the creation of new financial and technical institutions to support entrepreneurship. As in Silicon Valley, the advantage of developing in a new industrial location lies in the opportunity to create new institutions--and to escape the incentive structures and patterns of resource use defined by older, established industries.

Hsinchu, like Silicon Valley, is characterized by high rates of entrepreneurship, intense competition--as well as collaboration--among specialized firms, and frequent failure. One observer reports that in 1997, 1,373 Taiwanese IT companies were started and another 1,147 went out of business (Jonathan Moore et. al. "The Taiwan Touch" *Business Week*, May 25, 1998.)³ This has contributed to a deep and diversified infrastructure of IT-related SMEs that provide the components, parts, and design services needed to produce desktop PCs, notebooks, and other information appliances and electronic systems: including logic and memory ICs and low-end CPUs, motherboards, PCBs, monitors, scanners, mice, power supplies, printers, boards/cards, peripherals, network and communications devices, and software.

The Hsinchu industrial system thus constitutes an almost complete component design and manufacturing supply chain for IT in a small geographic area, although Taiwan still depends on outside providers of high-end microprocessors, hard disk drives, and some memory chips, and most local firms lack the distribution and marketing capabilities that would allow them to successfully develop their own branded products. *See Figure 10.* Most observers stress the speed, flexibility, and innovative capacity of Taiwanese IT producers relative to their leading competitors--as well as their ability adapt, diversify, and upgrade in response to changing markets and technologies.

The extent of the vertical disintegration in Taiwan's IT industry is apparent in the semiconductor industry. Taiwan today is the home to 224 specialized semiconductor establishments, including 115 in IC design, 5 IC mask-makers, 3 wafer manufacturers, 6 IC chemicals producers, 20 IC fabrication plants, 30 IC testing plants, 36 IC packaging establishments, and 9 lead frame makers. *See Figure 11.* A similarly deep and detailed social division of labor characterizes the other segments of the IT sector. For example, Taiwan's PC manufacturers typically source components and parts from more than 100 different suppliers and subcontractors.

And like Silicon Valley, Hsinchu provides an environment in which small companies can grow large, while still remaining a part of this decentralized infrastructure. The early start-ups in IC manufacturing sector, Taiwan Semiconductor Manufacturing Co. (TSMC) and United Microelectronics Co (UMC.), have grown into corporate giants. Motherboard and PC system producers such as Acer and FIC are now also large and diversified. And in recent years, traditional Taiwanese conglomerates such as Formosa Plastics have increasingly invested in the IT sector. It is worth noting, however, that the new IT firms are typically professionally run, venture funded businesses that are very careful to avoid

³ It is best to regard these numbers, like the earlier data on the total number of electronics companies, as indicative of the scale of activity rather than as precise figures, since the estimates from different sources vary significantly.

the business practices of traditional family-run Chinese companies--in large part because of the management models brought by returnees from the US.

The activities of local educational, research, and financial institutions, and industry and professional associations--both public and private--are best understood as part of this decentralized industrial system. Publicly-funded institutions such as ERSO, public, profit-making organizations like the Institute for Information Industry, which provides research and education for the software industry, private institutions such as the Taipei Computer Association and the Taiwan Venture Capital Association, and the alumni associations of the Taiwan's leading universities all provide collective goods such as market and technical information, training, and coordination to Hsinchu producers--resources that tend to be underprovided by small specialized firms that lack the ability to capture the benefits of such long term investments.

The Hsinchu region, like Silicon Valley, thus appears as an exemplar of Marshallian external economies, in which the localization of skill, specialized materials and inputs, and technological know-how generate cost reductions for individual firms and increasing returns to the region as a whole. This concept, like that of a "cluster," explains why firms in the same industry co-locate, creating distinct agglomerations. However it provides limited insight into the mechanisms by which producers in a regional economy like Hsinchu emerge as global competitors and continue to adapt and add value in a fast changing environment. How, for example, did Taiwanese firms enter the market? Why do its specialized firms innovate rather than descending into mutually destructive cycles of cost-cutting competition that undermine the basis for growth? How do they prevent the migration of their customers to still lower cost production locations?

Neither of the concept of external economies nor that of an industrial cluster can account for the divergent trajectories of apparently comparable regional economies. For this, we need to better understand how production is organized. This is clear in the comparison of the differing organization and performance of Taiwan and South Korea in PC manufacturing and assembly. Levy and Kuo (1991) compare the "bootstrap" strategy of small Taiwanese firms and their high propensity for risk-taking and experimentation with the high volume assembly strategy of large, vertically integrated Korean conglomerates. They conclude that Taiwan's extensive supplier and subcontracting infrastructure produces an ongoing stream of innovation-intensive SMEs, as well as the opportunity for some firms to achieve technological mastery and grow large. The Korean chaebol, by contrast, have failed to keep up with shorter product cycles for PCs, and in the 1990s fell so far behind that they were forced to source key components like motherboards from Taiwan (Chung, 2000).

The comparison between Taiwan and Singapore is also instructive. Like Taiwan, Singapore was a destination for consumer electronics FDI in the 1960s and 1970s. Singaporean policymakers aggressively sought foreign investment in the following decades--tailoring local institutions and policies to the needs of foreign corporations. This strategy was successful: Singapore is now a major global producer of hard disk drives, multimedia sound cards, notebook systems, and inkjet printers (Callon, 1995). However at a time when Taiwan quickly diversified beyond FDI and developed a homegrown industrial base, the IT industry in Singapore remained overwhelmingly dominated by the subsidiaries or branch plants of multinational that left little scope for indigenous innovation. The manager of a Singapore-based PC producer complained in 1994 about Taiwanese dominance in motherboard manufacturing:

If I had my own choice I would do it myself. But we are way behind Taiwan . . . In fact their design capability exceeds anything in the United States as well. They can fax designs to you that afternoon. For years, they have been building up design cells, so when they need a new design, they pull together the appropriate cells, make some small changes, and they have a new design. (Callon, 1995, p. 8)

Taiwanese producers frequently cite their speed and a well-developed component supply infrastructure as key advantages in a very fast paced and uncertain industry. (This responsiveness distinguished these firms even prior to the adoption of Internet communications, and has more to do with organization than with technology per se.) In the 1993 words of C.S. Ho, President of the Mitac Group:

Time to mass production is critical. Taiwan has some cost advantage over US firms, but the real key is that we can act really fast . . . Parts can be in the critical path to fast ramp-up. It doesn't matter how small the part is, if its not there, you can't build the machine . . . [In Taiwan there are] lots of companies doing different things, lots of companies doing the same thing. The result is a virtuous and intensively competitive cycle that drives speed and innovation.

The Evolution of Industrial Decentralization: the PC Industry

Taiwan's PC industry started when local entrepreneurs began to imitate the Apple II and IBM PC in the early 1980s. Most of the early PC makers were small companies that had been making video game machines (copied from Japanese manufacturers) until 1982 when the Taiwanese government banned the playing of video games for 'moral' reasons. The shift from PCs was not difficult both because the PCs were designed as open systems, and because they were microprocessor-based products with similarities to video game machines. By 1983 there were more than 100 firms in Taiwan cloning the designs of Apple II and IBM PC systems. While Apple ultimately clamped down on pirating of the Apple II, the openness of the IBM architecture, combined with lax IP protection by the Taiwanese government, facilitated the explosive growth of Taiwan's PC industry.⁴

The first foreign PC firm in Taiwan was Qume, a firm run by Chinese-American entrepreneur from Silicon Valley who had been courted by top government officials. The founder of Qume, David Lee, reports that he came to Taiwan in 1982 for low cost labor and a financial package that included attractive loans and tax benefits. Qume gave OEM orders for IBM-compatible PCs to three Taiwanese companies: Acer, Mitac, and Compeq (Acer and Mitac were cloning Apple II at the time, Compeq was making calculators.)⁵ Lee describes sending a team from Qume to teach scores of engineers at these companies how to manufacture and test IBM-compatible PCs. Taiwan at the time was still very poor: Acer leased a shabby old garment factory in order to fulfill the contract, and Mitac was offered a contract to make \$30M worth of PCs, but could only accept \$15M.

⁴ The only part of the IBM PC that was not widely available off-the-shelf was the ROM-BIOS (that links and coordinates all of the hardware components with the operating system and applications software.) Taiwan's producers had not yet developed the technological capability to design the BIOS, so either acquired it through illegal imitation or, after 1985, from specialized US firms that reverse engineered it legitimately.

⁵ An OEM (original equipment manufacturing) arrangement is one in which the customer provides detailed technical blueprints and components that allow the contractor to produce a product that will be marketed under the customer's brand name.

The initial success of these early contracts expanded as a widening range of US customers turned to Taiwan for manufacturing of everything from complete PCs to disks, printers, terminals, monitors, peripherals, and other related parts. The initial OEM orders were motivated almost entirely by the lower cost of labor. Over time, however, Taiwanese producers began to upgrade their capabilities. This upgrading occurred mainly through an informal process of "learning by doing" as engineers first gained familiarity with the manufacturing process and then experimented by imitating and modifying circuit designs, and by making changes and improvements in products and in the debugging processes necessary for volume manufacturing (Lin, 2000.)

By 1990 Taiwan's PC companies had reached the technical forefront in PC manufacturing, although they still remained imitators, and the lag time between the introduction of a new PC product and the launching of a Taiwanese clone was down to six months or so. By that time, half of Taiwan's computer exporters served as OEMs, one-quarter manufactured their own brands (including Acer and Mitac), and foreign companies accounted for only a quarter of exports (Tengli Lin, 2000.) The pace of technical change increased and profit margins diminished rapidly in the early 1990s, forcing many Taiwanese producers out of business. However the industry as a whole flourished. *Business Week* referred to Taiwan's PC companies as "arms dealers to the world" in the computer wars of the early 1990s.

Taiwanese firms mastered both the design of motherboards and the efficient integration of entire PC systems in the 1990s. They acquired these skills by taking on a growing volume of OEM contracts, as well as greater responsibilities for new product design by shifting to ODM (original design manufacturing) relationships.⁶ The ODM relationship--in which the Taiwanese partner takes over the entire chain of design, engineering, production, inventory management, and worldwide logistics for a product--significantly expands the opportunities for participation with customers in product definition and development and requires more frequent interactions and transfers of tacit knowledge. This has allowed Taiwanese engineers to increase the pace of motherboard design and to improve the yield and quality levels in volume manufacturing.

The speed, quality, and flexibility of Taiwanese PC and systems companies has provided a tremendous competitive advantage in an environment of ever faster product cycles and competition based increasingly on time-to-market. According to Peter Kurz, Director of Merrill Lynch Taiwan, "The Taiwanese can lower costs faster than anyone else while maintaining top quality. Sub-\$1,000 PCs have forced Compaq and IBM out of manufacturing, which they've turned over to the Taiwanese." By the end of the 1990s Taiwan was the dominant manufacturing base in the global PC industry. First-tier computer firms from the US and Japan including Compaq, IBM, NEC and Fujitsu relied on Taiwanese producers for product design and logistics (ODM) as well as manufacturing (OEM) of Servers, Desktop PCs and Notebook PCs. See *Figure 12*.⁷

Taiwanese companies continued to deepen and diversify the infrastructure in the 1990s by entering new businesses and by innovating incrementally on existing products. Systems assemblers expanded first into notebook and laptop PCs and more recently into mobile phones, palm PCs and other information appliances. See *Figure 13*. New start-ups as well as established companies also began

⁶ In ODM (original design manufacturing) the contractor takes on the added responsibilities for product design as well as most component procurement and logistics.

⁷ Dell has pursued a distinctive path from other PC makers by purchasing motherboards and other components from Taiwan but doing its own final assembly. The exception is laptops which it OEMs from Taiwan's Quanta and Compel. However even with laptops, installation of the MPU is done at a Dell factory.

producing CD-ROMs, modems, and TFT-LCDs. While Taiwanese companies are still technological imitators, they are expected to become the leading producers in each of these markets very soon.

In a recent example of innovative adaptation, three Taiwanese manufacturers of MP3 players responded to sharply falling profits by developing new MP3 players that feature CD-R discs (recordable compact discs.) These companies claimed that the CD-R disc would provide a far less expensive form of storage (and hence a substantially cheaper product) than the flash memory chips currently used in MP3 players. All started production in late 2000, with a collective initial capacity of over 50,000 units per month. This new product was developed to restore their profitability (at least in the short run) since the new CD-R drive cost less than \$1.50 per unit.

While this does not represent technological innovation of the sort that we see in Silicon Valley, it is typical of the incremental innovation and rapid commercialization that distinguishes the Taiwanese IT industry. Hsinchu companies have continued to build on their accumulated manufacturing experience, and on close relationships with local component makers (including IC designers and fabricators) to quickly design and produce lower-cost variants of existing products. In some cases, they have developed and designed entirely new products. The competitiveness of this system is reflected in the continuing announcement of new contracts from global technology leaders: from Toshiba and Sony for laptop computers, and from Nokia and Ericsson for wireless phones.

The Evolution of Industrial Decentralization: the IC Industry

Taiwan's IC design and manufacturing capabilities evolved in parallel with, but largely separate from, the PC industry prior to the 1990s. U.S. multinationals like General Instruments established semiconductor packaging and testing facilities in Taiwan in the 1960s and 1970s to take advantage of low-cost labor. But unlike PCs, the FDI in semiconductors provided no backward linkages to the more complex and costly processes of chip design and manufacturing. And although local universities had started research and training in electrical engineering, the design and fabrication processes required a higher level of technological skill and knowledge than existed in Taiwan at the time.

The Taiwanese government initiated this process of technological upgrading by making substantial investments in seeding an indigenous capacity for IC manufacturing. ERSO officials chose to transfer production technology from abroad and to focus on custom chips (or application specific integrated circuits, ASICs) rather than the capital intensive high volume memory chips that would put them in direct competition with Japan and the US.⁸ In 1976 ERSO established Taiwan's first wafer fabrication plant, signed a five-year technology transfer agreement with the American consumer electronics firm, RCA, and sent a team of 37 Taiwanese engineers to an RCA facility in the US for a year of training in IC design and manufacturing.⁹ The ERSO team returned and in 1977 began to design and manufacture chips on a small scale for commercial uses in Taiwan. This team (now known as the RCA-37) in turn formed the core of the leadership of Taiwan's IC industry in subsequent decades.

⁸ In addition to pursuing a niche market, ASICs, rather than competing head on with the industry leaders, this strategy differentiated Taiwan from Korea, which pursued the high volume products like memory.

⁹ The agreement stated that RCA would provide to Taiwan the technicians, technical training in the US, and design and manufacturing capabilities, including transferring all technological advances and design and process improvements for making CMOS devices. RCA also agreed to purchase back a certain quantity of wafers produced by the plant, and to provide information on product applications. See Hsu, 1997.

In addition to sponsoring technological learning, policymakers also insured that new technology was commercialized rather than remaining within government labs. Taiwan's first semiconductor firm, United Microelectronics Company (UMC), was established in 1979 as a spin-off from ERSO with a 45% equity share held by five local private firms. UMC was run by one of the RCA-37, staffed with ERSO engineers and used ERSO research, but operated as a private, profit-making enterprise. In 1982 UMC completed a state-of-the-art fabrication facility for ASICs in the Hsinchu Science-based Industrial Park, which became the core for the subsequent clustering of IC designers and producers. And 1983 UMC formed partnerships to with three Chinese-run semiconductor companies that from Silicon Valley in order to bring their design capabilities up to world standards.

Taiwan's senior officials maintained close ties with the Overseas Chinese in the 1980s, and succeeded in recruiting Morris Chang to return to Taiwan to head ITRI in 1984. Chang, a Taiwanese engineer with a PhD from MIT, had spent over 20 years at Texas Instruments, including most recently as CEO. Chang remained at ITRI for one year before becoming the CEO of the new Taiwan Semiconductor Manufacturing Corporation (TSMC)--a \$135M venture financed jointly by the Taiwanese government (48%), Philips (27.5%), and local private investors. Like UMC, TSMC focused on production of ASICs, rather than competing directly with industry leaders in memories. With technology from Philips, TSMC built a state-of-the-art manufacturing facility in the Hsinchu Science Park and quickly achieved yields and costs comparable to those in Japan and the US.

TSMC pioneered the OEM model in ICs, by building a "foundry" that specializes solely in manufacturing ICs. This organizational innovation spawned scores of independent chip design specialists in Taiwan and abroad because it freed start-ups from the substantial capital investment required for a semiconductor manufacturing facility. By 1990, Hsinchu was home to 58 chip design firms, many of which were run and/or staffed by ERSO engineers. While Taiwan's chip design capabilities are not as sophisticated as those in Silicon Valley, they have been crucial to the development of the local PC industry. The "foundry" model also allowed TSMC to focus entirely on improvements in the technologically sophisticated process of fabricating increasingly small and complex ICs. TSMC quickly became one of the island's largest and most profitable IT companies, and its leading competitor, UMC gradually transformed itself into a foundry as well.

The Hsinchu Science-based Industrial Park, with TSMC and UMC and a quickly growing cohort of design firms, became an attractive location for Chinese engineers returning from the US. The growing ties between Silicon Valley and Hsinchu contributed directly to the Park's accelerated growth during the 1990s. By 1999 firms in the Science Park employed 74,7000 workers and accounted for \$9.5B in sales. This included 116 IC design and manufacturing companies, 50 computers and peripherals, 45 telecommunications, 45 optoelectronics, and 28 firms in other industries.

The technological capabilities of Hsinchu producers are reflected both in R&D spending and patents. In 1997 the companies in the Science Park collectively spent approximately 6.2% of their sales revenue on R&D, compared to only 1% for Taiwanese manufacturing as a whole. The IC and telecommunications industries devoted 8% and 8.5% of sales respectively to R&D. And IC design houses on average invested more than 10% of sales on R&D, including Weltrend and Realtek that invested 18% and 14% of sales respectively. The computer and peripherals industries, on the other hand, spent only 3.4% of sales on R&D. These investments have paid off patents. In 1997 Hsinchu's IC producers collectively received 788 US patents; and TSMC and UMC both ranked among the top 10 recipients of US patents in the semiconductor industry (Science Park Administration, *Science-Based Industrial Park, 1998*, Hsinchu, Taiwan, 1999.)

Proximity bred intense competition between local IC producers, as well as collaborations with leading fabless design firms and equipment manufacturers, which has helped to accelerate technological progress in the industry. The following figure demonstrates the co-existence of strategic partnerships and competition within different segments of Taiwan's IC industry.

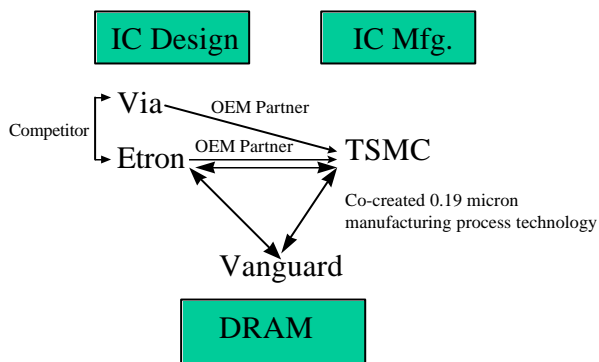

By the late 1990s TSMC and UMC had achieved technical parity with the US and Japan while remaining the world's lowest cost semiconductor producers. In 1999, the two firms jointly accounted for 66% of the world foundry market and \$4.3B in sales.

As the IC industry expanded and matured, it became increasingly integrated with the Taipei-based cluster of PC and component makers. Chip designers began to collaborate more closely with PC and peripherals manufacturers to design application-specific chips for their products, and these specialized chips were in turn manufactured at local foundries. As entrepreneurs defined new products, they relied on previous partners as well as new suppliers and designers to develop and manufacture these items quickly. This diversification and expansion of local customer-supplier linkages continues to enhance the adaptive and innovative capacity of the cluster.

By the end of the 1990s Taiwan's manufacturers were at least as profitable as their US counterparts, and many were significantly more profitable. *See Figure 14.* Some sectors such as ICs, printed circuit boards, and resistors and capacitors recorded average rates of return over 15% between 1995 and 1998. Eight companies recorded profits over 20% on average during the period: UMC and TSMC (IC manufacturing), Via (IC design), Asustek (motherboards), Compeq (printed circuit boards), Delta (switching power supplies), Yageo (resistors and capacitors), and Ritek (storage peripherals). And Taiwan's notebook manufacturers Quanta (18%) and Compal (14%) were more profitable than their customers Dell (11%) and Gateway (7%) and substantially more profitable than US contract manufacturers Solectron (3.5%) and SCI (5.6%). *See Appendix A.*

In short, the continuous diversification and deepening of the industrial infrastructure of Hsinchu underscores the economic value that can be created through a system of entrepreneurship-led growth. The integration and flexibility of the shifting networks of specialists in the region, combined with close ties to Silicon Valley's technology and market information, has generated substantial wealth for Taiwan.

Towards an Explanation of Hsinchu's Dynamism

Taiwan's success as an imitator made it an increasingly important partner and collaborator for Silicon Valley. However imitation did not involve direct competition with producers in Silicon Valley. By specializing in the manufacturing of ASICs and PCs Hsinchu emerged as a complementary (rather than competitive) cluster at a time when limitations of space and skill made manufacturing in the US increasingly uncompetitive. This focus also allowed Taiwanese start-ups to avoid the substantial costs of branding, marketing and distribution of IT products, and it allowed some firms to grow very large in spite of the limited size of the domestic market. Through partnerships with leading foreign PC and IT companies, Taiwanese firms have continued to innovate in both manufacturing and design of increasingly sophisticated products.

The adaptive capacity of Taiwan's IT sector derives from the decentralization of the industrial system, on one hand, and its close economic connections to Silicon Valley, on the other. The fragmentation and localization of production in the Hsinchu region--as in Silicon Valley--underlies the flexibility, speed, and innovative learning-by-doing of its firms, while the global connections insure that its small and specialized producers remain at the leading edge of markets and technology. While the local and global are increasingly closely integrated in this process of reciprocal innovation, they are discussed separately here for analytical purposes.

The Advantages of Localized Decentralization

The experience of both Hsinchu and Silicon Valley suggest that there are significant economic advantages associated with firm specialization and the deepening social division of labor. A decentralized industrial system enhances speed and responsiveness because it reduces barriers to entry, encourages experimentation, and allows for greater focus and flexibility. The small and medium-sized firms that characterize such a system are typically able to move faster and more flexibly than larger companies because they are less likely to be constrained by vested interests or established bureaucracies. These advantages of speed and flexibility are particularly important in a volatile, uncertain environment like that of today's IT industry.

There are also economic efficiencies associated with industrial decentralization. Vertical disintegration spreads the risks and costs of new product development across multiple firms. Specialist firms in such an environment also gain scale economies by serving multiple customers, and benefit from the ability to learn cumulatively from the experience of serving customers in different markets. This is a particular advantage in manufacturing. And while vertical and horizontal specialization continually create new entrepreneurial opportunities the intensification of competition between similarly specialized firms in turn stimulates further productive efficiencies.

Location in such an environment in turn enhances a firm's ability to identify and respond quickly to potential market niches. One Taiwanese engineer explains that while Taiwanese companies have not pioneered fundamental innovations, "Taiwan has been able to add creative features to high tech products tailored to the needs of different customers through timely information gathering, rapid reaction to macro trends, and attention to details and product modification." (Common Wealth, 7/1/96)

Indeed a deepening social division of labor enhances the innovative capacity of the entire industrial system because of the conceptual advances associated with the process of specialization and recombination. A specialist firm can focus and innovate in a narrow realm, while relying on other specialists to do so in their own areas. This tends to advance technology more rapidly than a single firm trying to innovate in many distinct areas. The process of integrating these specialist components into end products in turn stimulates further innovation. The entrepreneurial experimentation that characterizes a decentralized industrial system typically generates multiple, often unanticipated recombinations of specialized components and know-how to generate new products.¹⁰ This suggests that firm specialization increases the pace of innovation and ultimately economic growth.

The vulnerability of system based on increasing specialization is fragmentation. The specialist producers in a decentralized industrial system depend heavily on local social structures and institutions that coordinate adaptation and joint problem solving.

In the Hsinchu region, as in Silicon Valley, engineers move frequently between firms and between sectors; and there is a community of senior engineers who move not only between firms, but also between the public and private sector, between universities and the private sector, between the manufacturing sector and the venture capital industry, and between Taiwan and Silicon Valley. They meet regularly at alumni gatherings and class reunions, professional association meetings, industry conferences and trade shows, and a variety of related social events. In these forums they maintain relationships, exchange technical and market information, establish business contacts, learn about sources of capital and skill, and conceive of new ventures.

The intense communications within this technical community fosters imitation, joint problem solving and the transfer of information and know-how about management, technology, the job markets, and new firms and products. And as in Silicon Valley, high rates of inter-firm mobility insure the diffusion of tacit knowledge and facilitate the process of new firm formation.

The alumni networks from Taiwan's technical universities--which trained the majority of local engineers--have been central to the development of the PC and IC industries. It would not be unusual for a Taiwanese engineer to call a former classmate in the middle of the night to get help solving a technical problem, and many have started companies with their classmates. Acer managers report they are far more likely to contact former teachers, classmates or colleagues when they encounter a business problem (engineering, marketing, manufacturing) than turn to a private consulting firm or institution. (Ernst, 2000) And of course networks among former colleagues and customers develop easily in such a localized environment. Acer, for example, has created a unique network of social contacts within Taiwan's PC industry through the training programs that it has provided for local computer engineers since 1976.

Of course shared experiences can also intensify competition in a localized community. According to a top executive at TSMC, "Engineers in the Hsinchu Science Park not only work very hard, but they share the same backgrounds. Most of them graduated from the same university, took the same classes, got taught by the same professors, and had similar work experiences at ITRI . . . There is no way NOT to expect competitiveness from such work teams!" (Common Wealth, 7/1/96)

¹⁰ Of course it is possible to specialize without innovating, and it is possible to innovate without changing the division of labor. However it appears that the growth of opportunities for experimentation generates ideas, these ideas are combined to make new ideas, and so forth in a dynamic and self-generating process.

The underlying trust among Taiwan's technical community has been crucial as well to coordinating business relations in a complex, fragmented production supply chain. It allows specialized producers to compete intensely while also collaborating, at least for the length of a given project, and to respond to quickly to changing markets and technologies. Close collaboration among networks of suppliers and customers is essential when both time to market and time to volume are key to competitive success, as in the present era, when product cycles continue to accelerate.

The Importance of the Connection to Silicon Valley

The performance of Taiwan's IT industry has been built on close economic ties to the U.S., and to Silicon Valley in particular. Today the flows of people, information and know-how, as well as more formal business partnerships, linking the two regional economies are so great that some claim Taiwan is "like an extension of Silicon Valley." This is not to suggest that Hsinchu is another Silicon Valley: the two regions remain at different levels of development and they are differently specialized. Silicon Valley remains a center of new product definition and leading edge innovation, while Hsinchu producers can rapidly adapt and commercialize technologies developed elsewhere. The relationship between the two economies is thus complementary, and increasingly so, rather than competitive.

Taiwan's IT producers have benefited from their growing role as manufacturing partners for the world's leading computer and systems producers, and from their deep integration into Silicon Valley's social and professional networks. The OEM relationship, in both PCs and ICs, provided the volume manufacturing experience that allowed Hsinchu firms to "learn by doing" and to incrementally improve their capabilities because production information and know-how is transferred in the relationship between customer and supplier, particularly as the partnership deepens with time and the increasing sophistication of products.

The social and professional networks of an international technical community, while less formal than international production contracting networks, are also being institutionalized in a professional associations and venture capital partnerships. Many Chinese engineers in Hsinchu and Silicon Valley are members of associations like the Chinese Institute of Engineers (CIE.) While formally dedicated to technical exchange, CIE also helps to build relationships and reproduce the trust among the members of a far-flung community through frequent conferences and professional exchanges.

The Taiwanese government actively encouraged the development of a social and professional bridge between the two regional economies as well. Agencies such as the National Science Council and ITRI established offices in Silicon Valley in the 1980s, long before it was fashionable. These agencies sponsored the formation of the Monte Jade Science and Technology Association to promote "cooperation and the mutual flow of technology and investment between Taiwan and the U.S." Its membership includes the leading Taiwanese companies based in both Silicon Valley and Taiwan; and its annual conference in Silicon Valley, which is the most important professional event for the region's Chinese technical community in the region, typically draws more than 1,000.

Venture capital has become increasingly global as well. Chinese-run venture firms from Silicon Valley have opened offices in Taipei to monitor investment opportunities—and Taiwanese venture firms (or funds for large companies like Acer or TSMC) have expanded their investments in Silicon Valley. These new venture capitalists have developed a web of alliance patterns linking investors, entrepreneurs, and established firms in the two regions (Saxenian and Li, 2000.) Ken Tai, one of the

co-founders of Acer and now the managing director of Investar, sees his firm as a bridge linking Silicon Valley's new product designs and technology and Taiwan's chip manufacturing and system integration capabilities.

The new technology is all in Silicon Valley, but when you want to integrate that technology into a final product, Taiwan is the best place. Taiwan is the best place to integrate technology components together in a very efficient way because it excels at production logistics and information handling.

Tai goes on to describe the role of venture capital firms like InveStar in this process:

When we invest in Silicon Valley startups we are also helping bring them to Taiwan. It is relationship-building . . . we help them get high-level introductions to the semiconductor foundry and we help establish strategic opportunities and relationships in the PC sector as well. This is more than simply vendor-customer relationships. We smooth the relationships.¹¹

While many Taiwanese returned home, others like Ken Tai are part of a growing population of "astronauts" who work in both places and spend much of their time on airplanes. As engineers travel between the two regions they carry technical knowledge as well as contacts, capital, and information about new opportunities and new markets. The information moves almost as quickly *between* these distant regions as it does within Hsinchu and Silicon Valley because of the density of the social networks and the shared identities and trust within the community. In the words of one Taiwanese engineer:

If you live in the United States its hard to learn what is happening in Taiwan, and if you live in Taiwan its hard to learn what is going on in the U.S. Now that people are going back and forth between Silicon Valley and Hsinchu so much more frequently, you can learn about new companies and new opportunities in both places almost instantaneously.¹²

Another engineer who worked for IBM in Silicon Valley for 18 years before returning to Taiwan says: "There's a very small world between Taiwan and Silicon Valley." (Barnathan, 1992) And the former CEO of Acer America claims that the continuous interaction between the Hsinchu and Silicon Valley has generated "multiple positive feedbacks" that enhance business opportunities in both regions.¹³

Fred Cheng, who runs Winbond North America claims that: "The best way to start a technology company today is to take the best from each region, combining Taiwanese financial and manufacturing strength with Silicon Valley's engineering and technical skill."¹⁴ This appears to be a classic case of the benefits of comparative advantage. However, the economic gains from specialization and trade depend on the social structures and institutions that insure flows of information and facilitate joint problem

¹¹ Ken Tai interview, Taipei, May 16, 1997

¹² C.B Liaw interview, Mountain View, August 28, 1996

¹³ Ron Chwang interview, Fremont, March 25, 1997

¹⁴ Fred Cheng interview, San Jose, March 25, 1997

solving between distant producers. The Taiwanese technical community--including engineers in the US and in Taiwan as well as "astronauts" who seem to live in the air--efficiently transfers information about investment and partnership opportunities as well as about markets and technology between Silicon Valley and Hsinchu.

The Hsinchu case suggests that the social structure of a technical community is essential to the organization of production at the global as well as the local level. In the old industrial model, the technical community was primarily inside of the corporation. The firm was seen as the privileged organizational form for the creation and internal transfer of knowledge, particularly technological know-how that is difficult to codify (Kogut and Zander, 1993). In regions like Silicon Valley, where the technical community transcends firm boundaries, however, such tacit knowledge is often transferred through informal communications or the inter-firm movement of individuals. An international technical community can likewise play a critical role coordinating knowledge transfers between distant decentralized regional economies.

In the current era, this entrepreneurial and bottom-up construction of long distance professional and business ties may prove to be as important as the global connections created by multinational corporations. This suggests that the multinational corporation may no longer be the preferred organizational vehicle for transferring knowledge or personnel across national borders. Transnational communities provide an alternative and potentially more flexible and responsive mechanism for long distance transfers of skill and know-how—particularly between very different business cultures.

Concluding Comments

The deepening social division of labor in the information technology sector has created opportunities for innovation in formerly peripheral regions—opportunities that did not exist in an era of highly integrated producers. By exploiting this opportunity in their home country, Taiwanese entrepreneurs have built an independent center of specialization and innovation, while simultaneously maintaining ties to Silicon Valley to monitor and respond to fast-changing markets and technologies. The specialist producers in Hsinchu are now well positioned to establish cross-regional partnerships that facilitate the integration of their specialized components into end products.

The case of Hsinchu demonstrates that connections *between* clusters may be as important as those within them in an increasingly global economy. Integration into global IT production networks and close ties to Silicon Valley provide a tremendous advantage to Hsinchu's producers by allowing them to quickly identify and respond to market opportunities, technological innovation, and potential competitors or partners. Other clusters of entrepreneurship-led growth such as Israel, India, and Ireland are building similar connections to Silicon Valley based on their own distinctive specializations.

The lessons for other regional economies are less clear-cut. Extensive public support of education and research were essential to Taiwan's success. So too were the early and close connections to Silicon Valley's technical community. While it is easy to define address the former through policy, the latter is far more elusive. In addition, while ITRI and ERSO played a critical role in the early development of Taiwan's IT industry by transferring leading edge technology to the IC industry, their recent attempts to develop technology have had less success. The timing (early in industries' life cycle) and focus (ASICS rather than memories) of the government investments reflected intimate knowledge

of technology and markets at the time. And now that Taiwan has established its role as the leading center of IC foundries the barriers to entry are much higher.

Today government agencies like ERSO and ITRI play a far more limited coordinating role in Taiwanese IT industry (Lin, 2000, Hsu, 1997). Their greatest legacy going forward may be as a very sophisticated training center: between 1973 and 1998, approximately 10,000 ITRI researchers left the agency to join the private sector, taking with them the skills and intangible technological capabilities and understandings that come from working in an advanced research laboratory.

The evolution of the Hsinchu cluster in coming decades will be increasingly tied to that of Mainland China. Following traditional Taiwanese industries such as textiles and garments, footwear, and consumer electronics that moved to the Mainland in the 1970s and 1980s, the PC industry began moving in the 1990s as competition intensified--particularly in low-end products such as power supplies, keyboards, mice, monitors and the assembly of desktop PCs. Most firms moved to the Dongguan area in Guangdong province to take advantage of wages one-tenth of those in Taiwan. Today the region now boasts a PC and components manufacturing infrastructure for low-end IT products that is as sophisticated as that in Taiwan. *See Figure 15.*

A more recent wave of Taiwanese IT investment that began in 1999 includes higher value added products including motherboards, video cards, notebook PCs as well as IC design, manufacturing and related infrastructure. This time the investment is focused in the Shanghai region, including both the Pudong district and Suzhou (a city to the west.) While these moves are still motivated primarily by the need to cut labor costs, Taiwanese industrialists also plan to exploit their linguistic and cultural advantages to (hopefully) capture privileged access the emerging China market. Government officials in China report that more than 3000 Taiwanese companies located in Shanghai in the 1990s, and that there are now approximately 200,000 Taiwanese living in the area.

Official data on Taiwanese IT investments in China represent only a portion of the total because such investments are illegal and, like the growing investments of venture capital from Taiwan, mostly channeled through Hong Kong. However even the official data show a significant recent increase in such investments, from a previous peak of \$875M in 1997 to \$1.5B in 2000. *See Figure 16.* Observers report that virtually all of Taiwan's PC and IC companies now have a presence in the Mainland; only the most technologically advanced manufacturers such as TSMC show no sign of moving across the Straits at present.

More comprehensive data indicate the scale of the shift that occurred in the 1990s. While production in China accounted for 14% of Taiwan's total output in 1995, by 1998 it had more than doubled to 29%.¹⁵ *See Figure 17.* And this data does not include the substantial growth that occurred in 1999 and 2000. If China's IT production continues to grow 30% per year, as indicated by Figure X, China will most likely overtake Taiwan as the world's third largest IT manufacturer in 2001.

By shifting manufacturing to the Chinese mainland, Taiwan is seeding new clusters of IT production. These clusters remain low cost manufacturing sites but as we have seen from the Taiwanese case, such investments develop the infrastructure and managerial and technical skill base that can support higher value production in the future. The movement of skill and technology from Taiwan to China shows no sign of slowing. In fact more than ---- Taiwanese companies in Shanghai

¹⁵ Approximately 90% of Taiwan's IT production is located in Taiwan or Mainland China. Small amounts of IT production are also in Thailand, Malaysia, and elsewhere.

alone. There is also an increasingly sophisticated community of US-educated engineers from Mainland China working in Silicon Valley.

The Chinese government, aware of the Taiwanese experience, is aggressively recruiting engineers to return from the US, while increasing investments in science and technology education and research, and in the telecommunications and physical infrastructure--including hundreds of high technology zones, parks, and incubators. While the evidence is clear that science parks alone do not insure IT growth, they can provide sophisticated infrastructure and services that might not otherwise be available a poor country like China. As in Taiwan, these parks (and the generous incentives and benefits associated with locating in them) could provide an easier transition for engineers returning from the US. However the more important variable will be their assessments of the professional opportunities available to them in each place.

Too much remains uncertain in the political and economic environment to make predictions about the future. However the experience of Taiwan and the other 'imitators' of Silicon Valley suggest that China's clusters could quickly achieve parity with the leading centers of IT production. These areas along China's east coast share several features with the other successful clusters: The new technology industries are emerging in new locations that are geographically distant from older industries and institutions and that boast advanced physical and telecommunications infrastructure. The firms in these clusters have access to ample supplies of low wage skilled workers, MNCs from around the world are training a large cohort of Chinese managers, and the Chinese government has increased its investment in science and technology-related research. There is a small but steady stream of returnees from Silicon Valley to start firms in these clusters, along with the continuing transfers of production and know-how from Taiwan. And unlike Taiwan, China has a potentially sizable domestic market.

The coming years will pose a serious challenge to the adaptive capacities of Taiwan's industrial system. Experts claim that Taiwan has only ten years before China reaches technological parity in manufacturing of even the most advanced ICs and IT products. During this time Taiwanese industry needs to establish new specializations, either as producers of higher value added software, content, and services and/or as manufacturers of distinctive systems and equipment that build on their existing strengths in designing, manufacturing, and recombining intermediate parts and components.

References

- Borras, Michael "Left for Dead: Asian Production Networks and the Revival of US Electronics" in Naughton, ed. *The China Circle* Washington, DC: Brookings, 1997
- Bresnahan, Timothy "New Modes of Competition: Implications for the Future Structure of the Computer Industry" Conference paper, March 1998
- Brookfield, Jonathan "Localization, Outsourcing, and Supplier Networks in Taiwan's Machine Tool Industry" Doctoral Dissertation, School of Management, University of Pennsylvania, 2000
- Callon, Scott "Different Paths: The Rise of Taiwan and Singapore in the Global Personal Computer Industry" Asia/Pacific Research Center, Stanford University, January 1995
- Chang, Pao-Long, Chiung-Wen Hsu, Chien-Tzu Tsai "A stage approach for industrial technology development and implementation—the case of Taiwan's computer industry" *Technovation* 19, 1999: 233-241
- Chang, Pao-Long, Chintay Shih, Chiung-Wen Hsu "The formation process of Taiwan's IC industry—method of technology transfer" *Technovation* 14 (3) 1994: 161-171
- Chang, Shirley L. "Causes of Brain Drain and Solutions: The Taiwan Experience" *Studies in Comparative International Development*. Spring 1992, 27 (1): 27-43
- Chung-Yuan Liu "Government's role in developing a high-tech industry: the case of Taiwan's semiconductor industry" *Technovation* 13 (5) 1993: 299-309
- Dedrick, Jason and Kenneth Kraemer *Asia's Computer Challenge: Threat or Opportunity for the United States and the World?* NY: Oxford, 1998
- Ernst, Dieter. "What Permits David to Defeat Goliath? The Taiwanese Model in the Computer Industry" Berkeley: Unpublished Paper, BRIE, University of California at Berkeley, 1998
- Granovetter, Mark "The Economic Sociology of Firms and Entrepreneurs" in A. Portes, ed. *The Economic Sociology of Immigration* NY: Russell Sage, 1995
- Hamilton, Gary "Organization and Market Processes in Taiwan's Capitalist Economy" in Marco Orru et al, eds. *The Economic Organization of East Asian Capitalism* Thousand Oaks, CA: Sage, 1997
- Hellman, Thomas "WI Harper International: Bridge between Silicon Valley and Asia" Graduate School of Business, Stanford University, SM-39, 1998
- Hobday, Mike "East Asian Latecomer Firms: Learning the Technology of Electronics" *World Development*. v. 23, n. 7, 1995
- Hsu, Jinn-yuh and AnnaLee Saxenian "The Limits of Guanxi Capitalism: Transnational Collaboration between Taiwan and the US" *Environment and Planning A*, forthcoming

- Hsu, Jinn-yuh. "A Late Industrial District? Learning Networks in the Hsinchu Science-Based Industrial Park" Berkeley: Doctoral Dissertation, Geography, University of California at Berkeley, 1997
- Kogut, Bruce and Udo Zander "Knowledge of the Firm and the Evolutionary Theory of the Multinational Corporation" *Journal of International Business Studies* 24, 4, 1993
- Kraemer, Kenneth, Jason Dedrick, Chin-Yeong Hwang, Tze-Chen Tu, and Chee-sing Yap "Entrepreneurship, Flexibility, and Policy Coordination: Taiwan's Computer Industry" *The Information Society* 12: 215-249, 1996
- Krugman, Paul *The Geography of Trade* Cambridge, MA: MIT Press, 1991
- Lau, Lawrence J. "The Competitive Advantage of Taiwan" *Journal of Far Eastern Business*, Autumn 1994
- Levy, Brian and Wen-Jeng Kuo "The Strategic Orientation of Firms and the Performance of Korea and Taiwan in Frontier Industries: Lessons from Comparative Case Studies of the Keyboard and Personal Computer Assembly" *World Development*. v. 19, n. 4, 1991
- Mathews, John A. "A Silicon Valley of the East: Creating Taiwan's Semiconductor Industry" *California Management Review*. v. 39, n. 4, Summer 1997
- Meany, Connie Squires "State Policy and the Development of Taiwan's Semiconductor Industry" in J. Aberbach et. al. *The Role of the State in Taiwan's Development* London: ME Sharpe, 1994
- Naughton, Barry, ed. *The China Circle: Economics and Technology in the PRC, Taiwan and Hong Kong*. Washington, D.C.: Brookings Institution Press, 1997
- Porter, Michael "Clusters and the New Economics of Competition" *Harvard Business Review*, November-December 1998
- Portes, Alejandro. "Global Villagers: The Rise of Transnational Communities" *The American Prospect*. pp. 74-77, March-April 1996
- Saxenian, AnnaLee and Chuen-Yueh Li "Bay-to-Bay Strategic Alliances: The Network Linkages Between Taiwan and the U.S. Venture Capital Industries" *International Journal of Technology Management*, forthcoming
- Saxenian, AnnaLee and Jinn-yuh Hsu "The Silicon Valley-Hsinchu Connection: Technical Communities and Industrial Upgrading" *Industrial and Corporate Change* forthcoming 2001
- Saxenian, AnnaLee. *Regional Advantage: Culture and Competition in Silicon Valley and Route 128*. Cambridge: Harvard University Press, 1994
- Trajtenberg, Manuel "Innovation in Israel, 1968-97: A Comparative Analysis Using Patent Data" Working Paper No 7022, National Bureau of Economic Research, Cambridge, MA. March 1999
- Wade, Robert. *Governing the Market: Economic Theory and the Role of Government in East Asian Industrialization*. Princeton: Princeton University Press, 1990

Figure 1

Market Share IT Manufacturing, Taiwan, 1997-1999

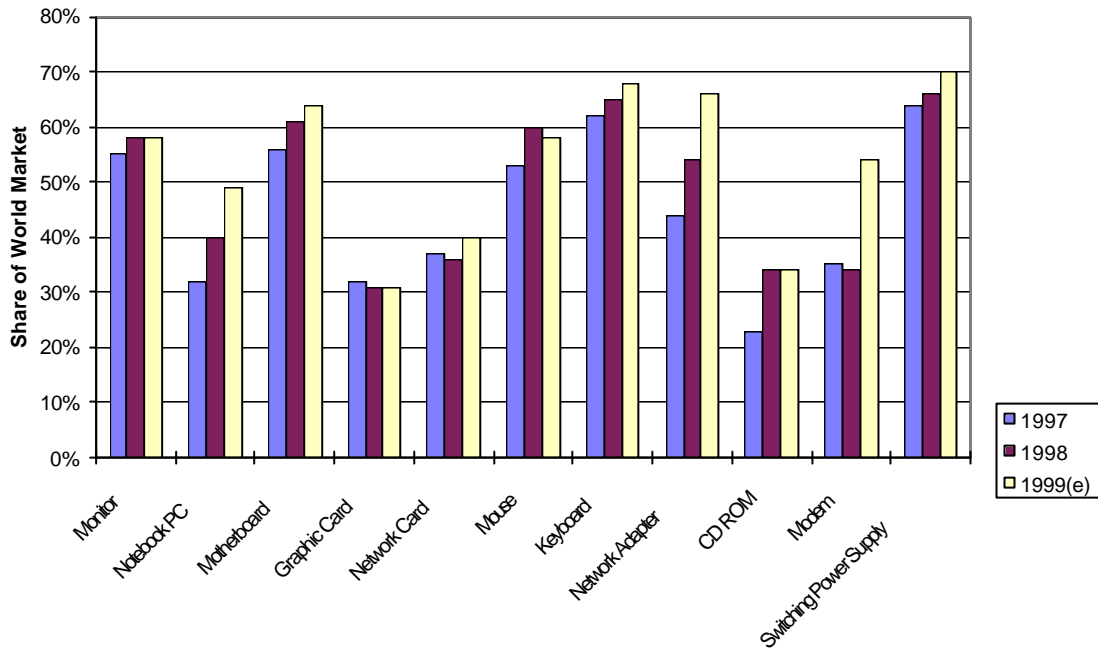

Source: MIC

Figure 2

Taiwan's Share of World Foundry Market, 1997-1999

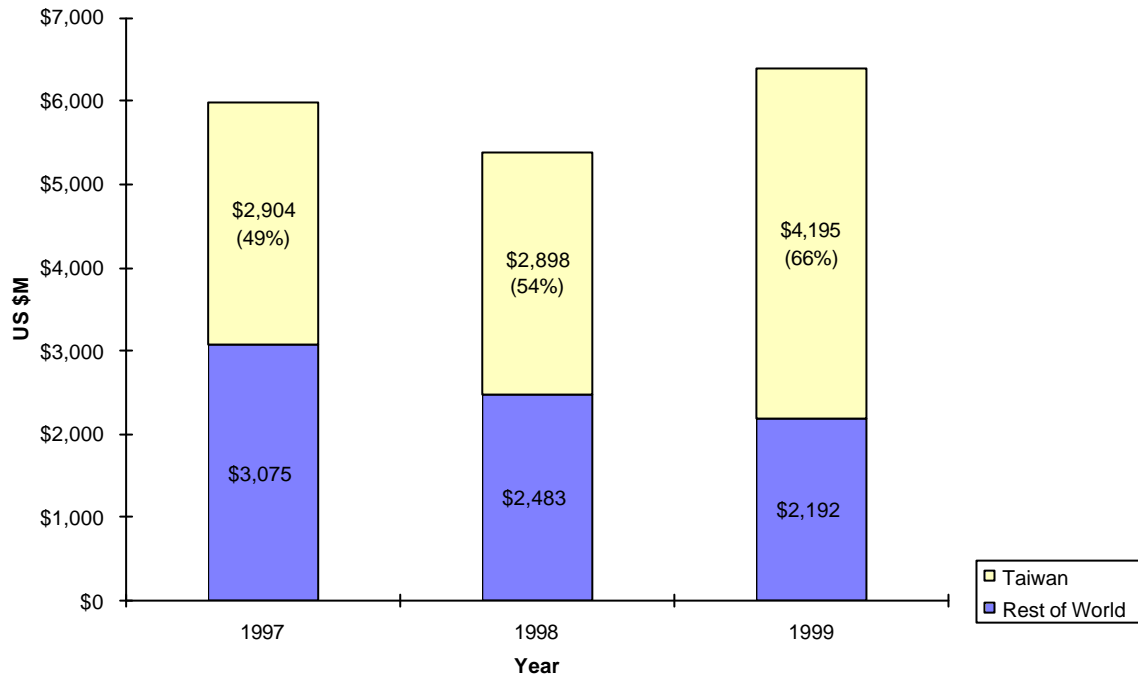

Source: ERSO/ITRI ITIS Project (Nov. 1998)

Figure 3. Domestic IT Output, Taiwan: 1981-1999

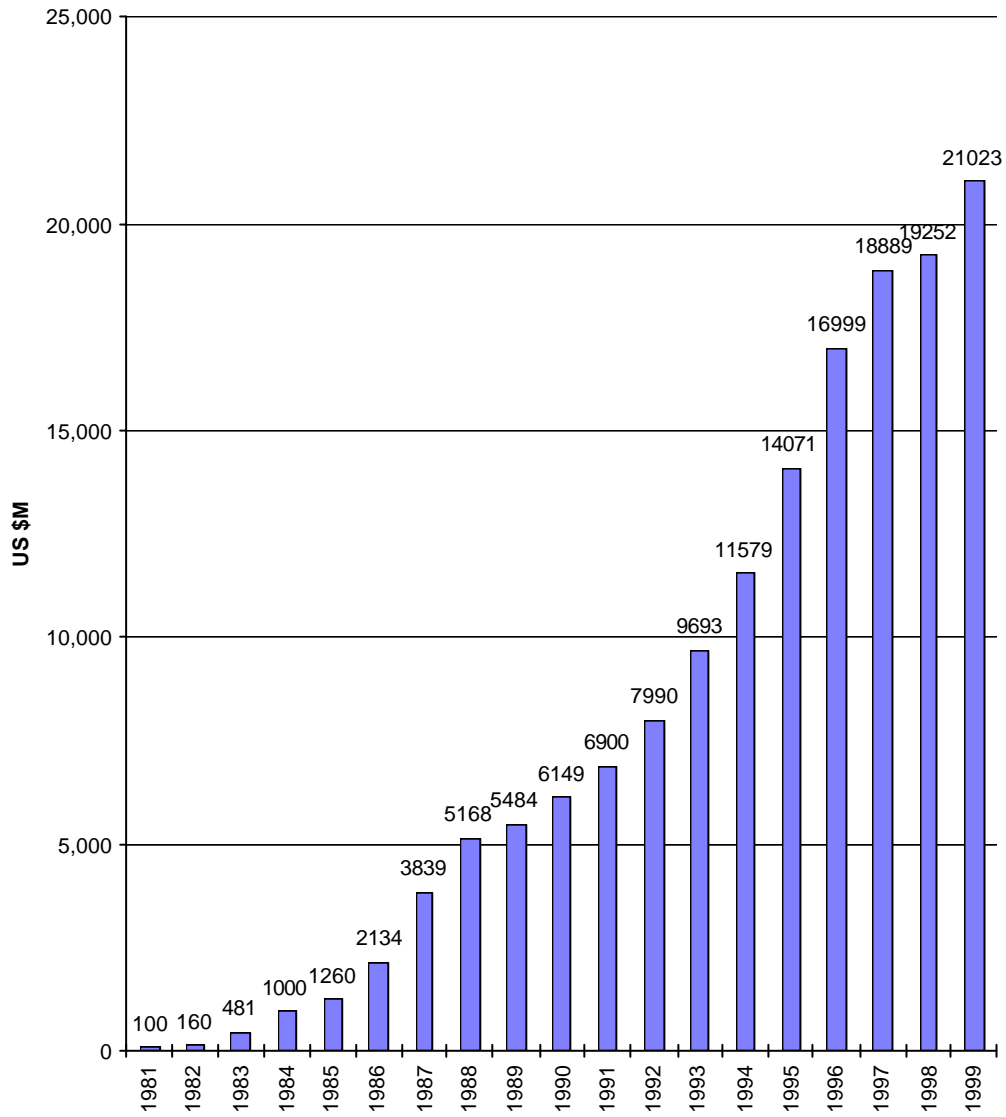

Source: National Youth Commission, Taiwan

Figure 4.

Total Value of IT Output by Country, \$M, 1998-1999

1999 Rank	Country	1998	1999	99/98 Growth Rate (%)
1	U.S.A.	90,630	95,162	5
2	Japan	42,558	44,051	4
3	Taiwan	19,240	21,023	9
4	Singapore	18,660	18,473	-1
5	China	14,196	18,455	30
6	British	15,398	15,552	1
7	Ireland	8,667	9,360	8
8	Germany	8,844	9,197	4
9	S. Korea	8,169	8,862	8
10	Brazil	8,395	8,227	-2

Source: MIC.

Note: 1999 is an estimate

Figure 5: Patents Per Capita for Taiwan, the NICs, and Israel.

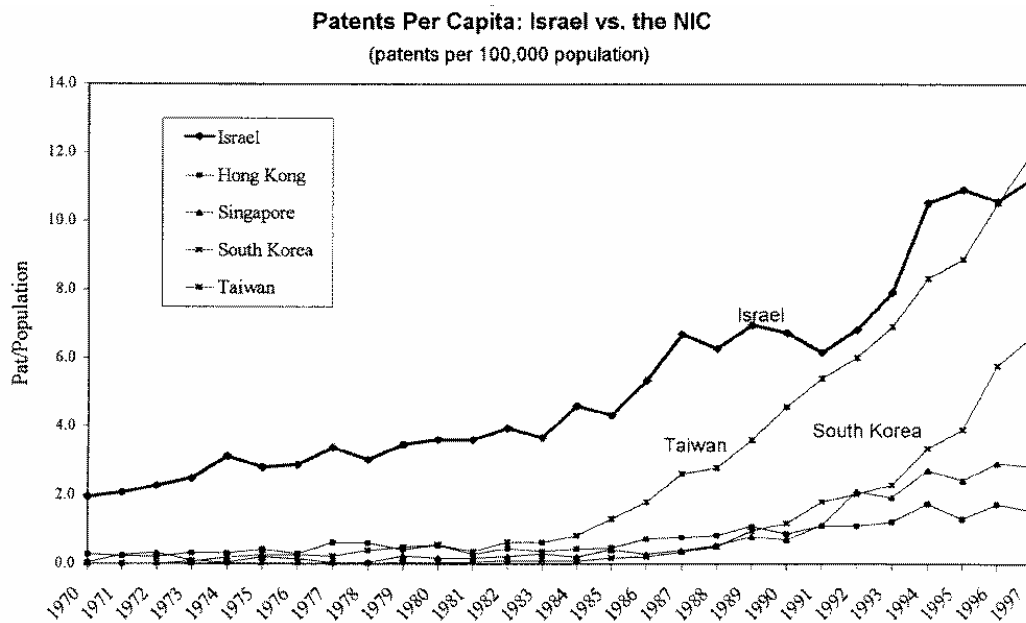

Source: <http://www.nber.org/papers/w7022>

Figure 6: Advanced Degrees in Taiwan, 1961-1996

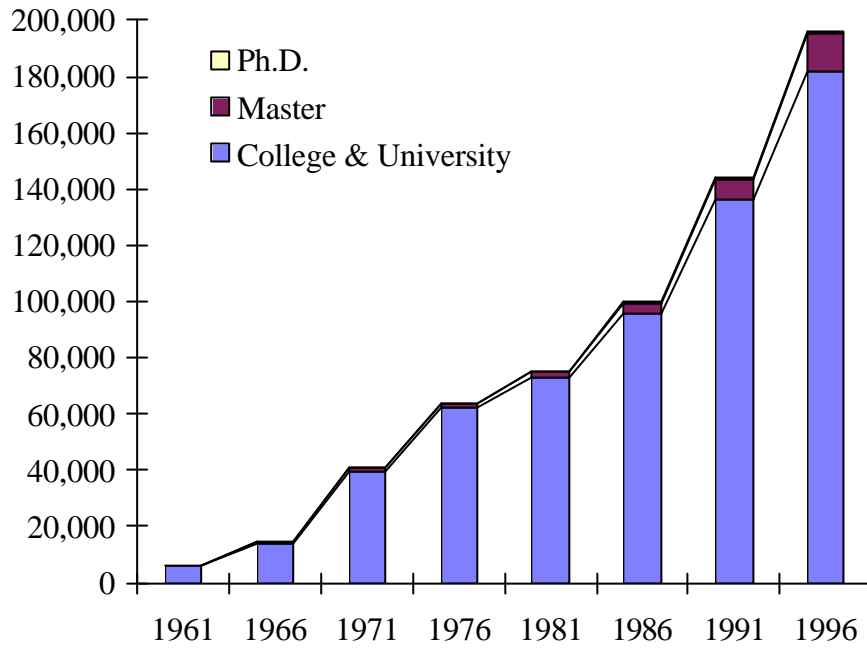

Source: Ministry of Education, Taiwan.

Figure 7. Returnees to Taiwan from the US: 1970-1997

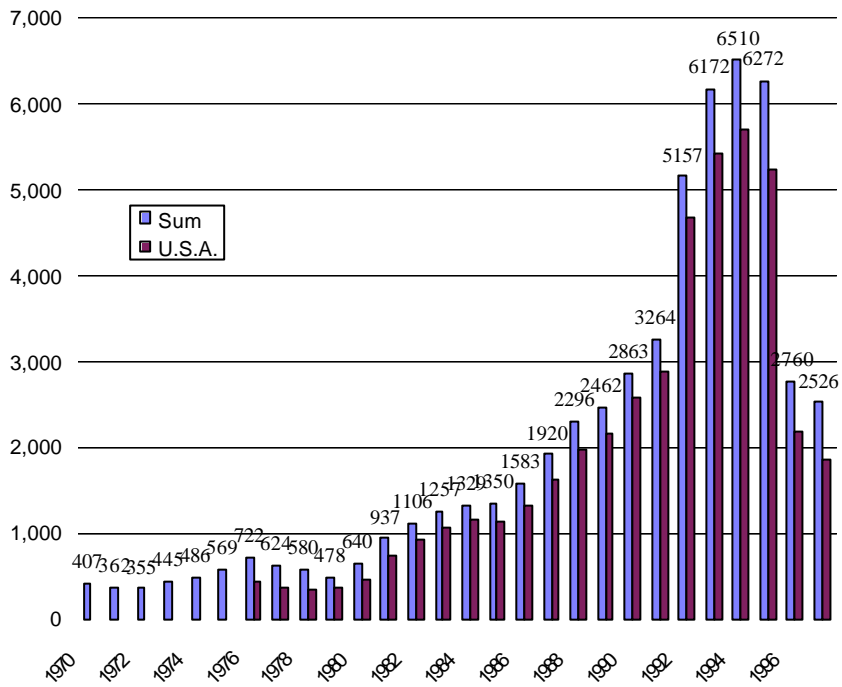

Source: National Youth Commission, Taiwan

Figure 8. Cumulative Venture Capital Investments, Taiwan: 1984-1999

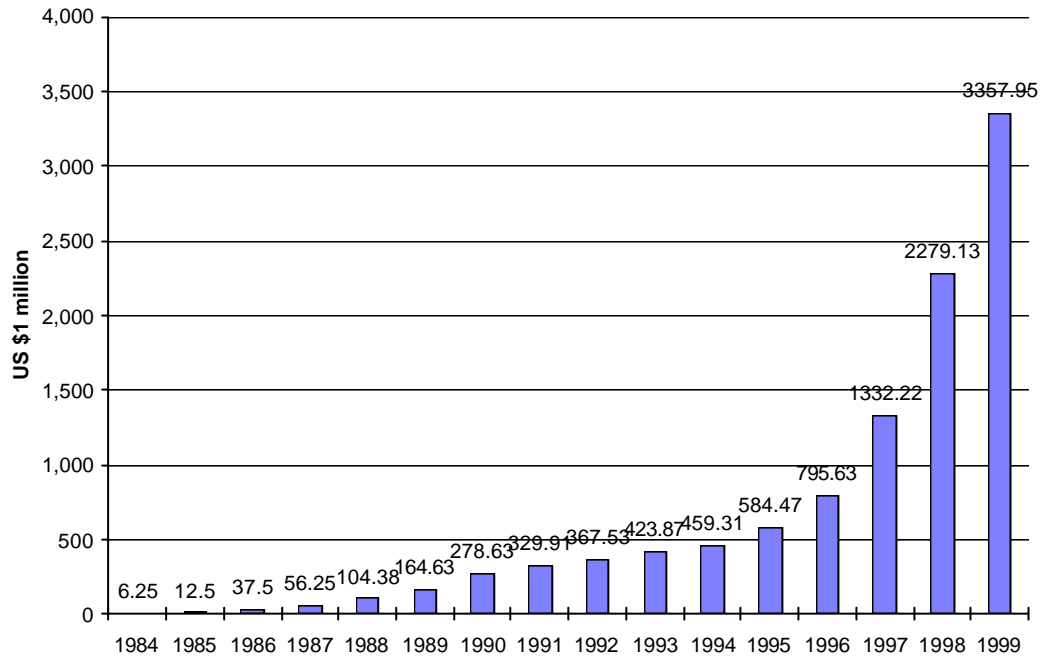

Source: 1. TVCA, Venture Capital in Taiwan, 1998 Edition
2. <http://www.tvca.org.tw/p12-1.htm>

Figure 9. Hsinchu Science Park, Annual Sales, 1986-1999

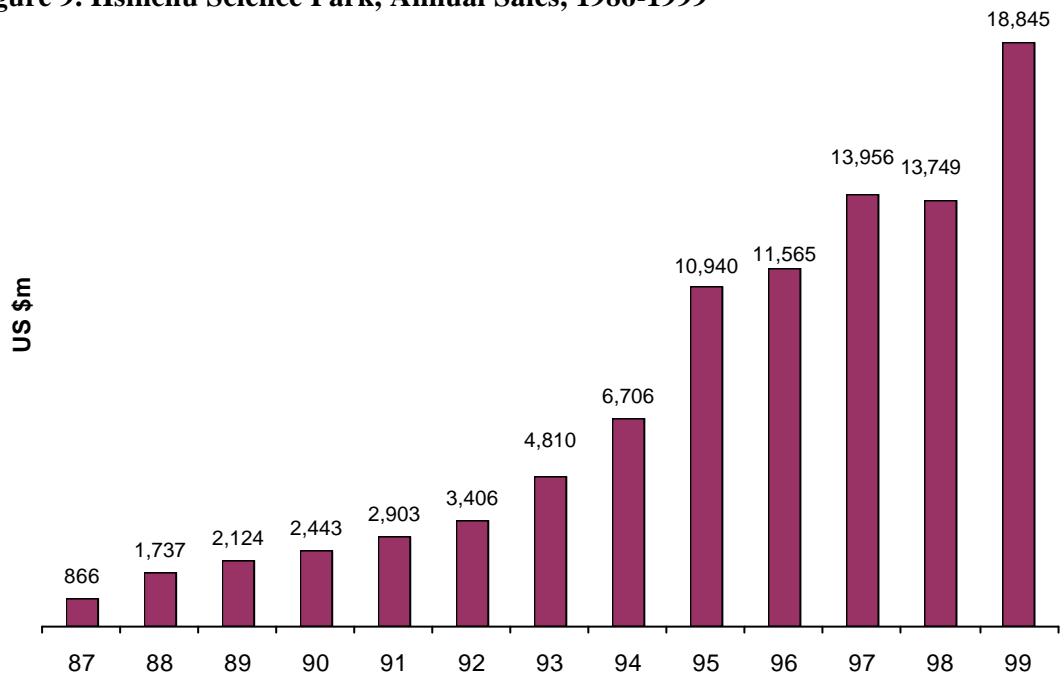

Source: Science Park Administration, HSIP

Figure 10: Taiwan's Information Technology Industry Supply Chain

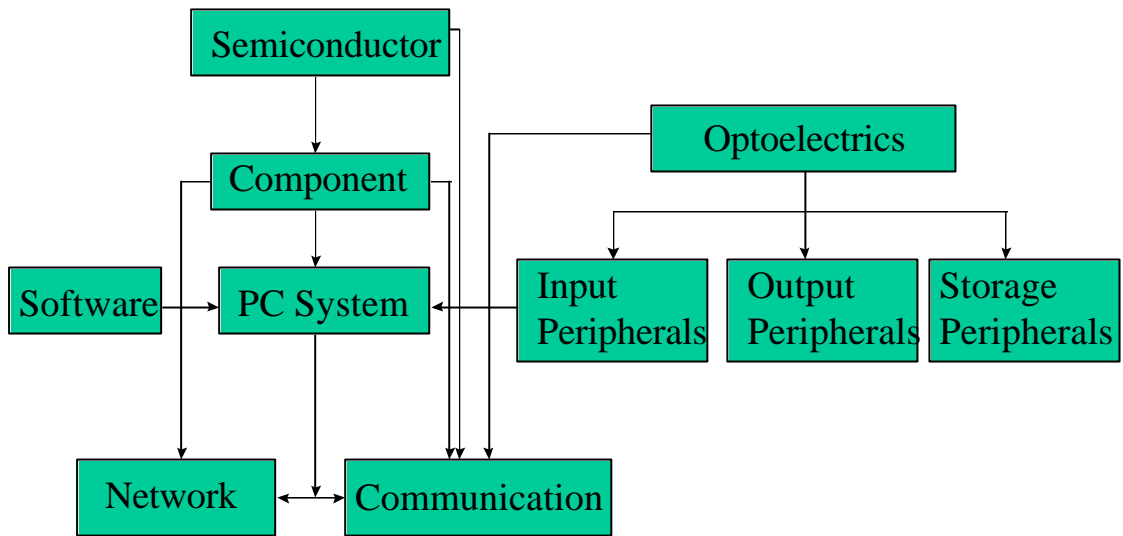

The Network of Taiwan IT Industry

PC System: Desktop PC, Notebook PC

Semiconductor: IC Wafer, IC Design, IC Fab, IC Packaging

Component: Mother Board, Power Supply, PCB, Network Card, Multimedia Card

Optoelectrics: LCD (for notebook PC and monitor), CCD (for scanner, digital camera), LED, critical components of CD-ROM

Input Peripherals: Mouse, Keyboard, Scanner

Output Peripherals: Monitor, Printer

Storage Peripherals: Floppy Disk, Hard Disk, CD-ROM

Software: Software Packaged, Games

Network: Data Communication (LAN, Internet, etc.)

Communication: Telecommunication (CO Switching, Wired Transmission, Wireless Transmission, Wired CPE, Wireless CPE)

Source: C. Wang, "The Information Technology Industry @ Taiwan", The Financial Information, Taipei, Taiwan, 1999.

Figure 11: The Structure of Taiwan's IC Industry

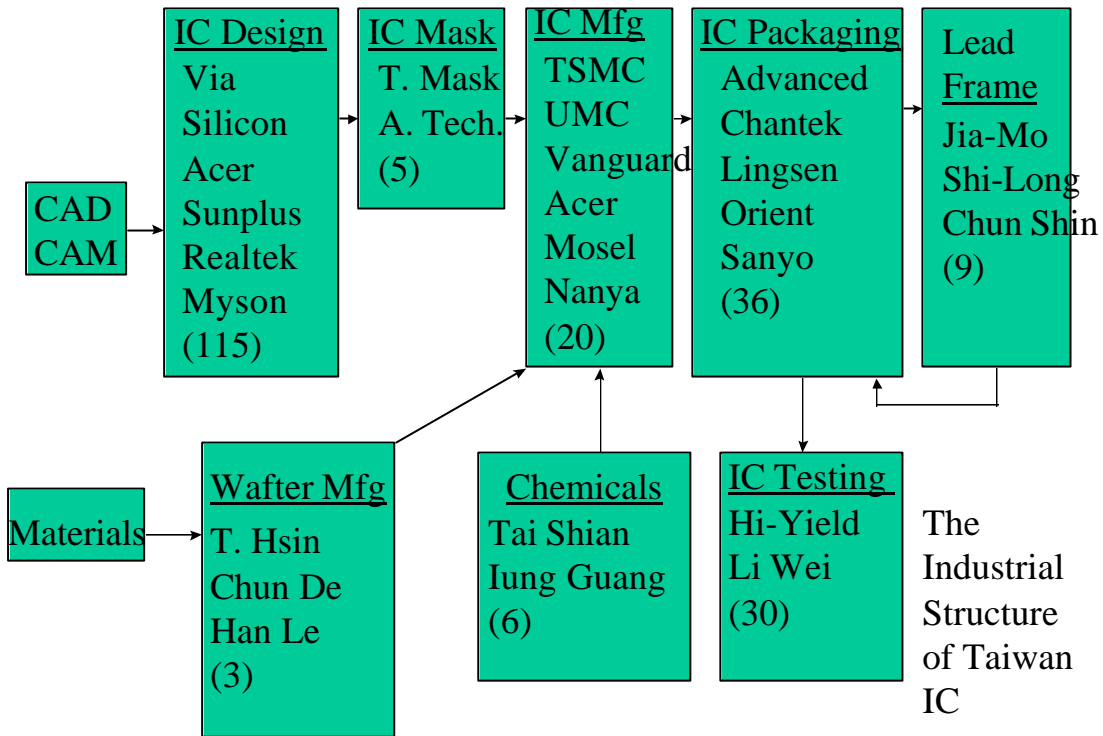

Source: C. Wang, "The Information Technology Industry @ Taiwan", The Financial Information, Taipei, Taiwan, 1999.

Figure 11: Personal Computer OEM Customers and Taiwanese Partners, 1999

Taiwan Companies	OEM Customers
Mitac (Desktop PC)	HP, Compaq
FIC (Desktop PC)	HP, Compaq
Ta-Tung (Desktop PC)	HP
GVC (Desktop PC)	HP
Mitac (Notebook PC)	Compaq, HP, SUN
Inventec (Server, Desktop PC, Notebook PC)	Compaq
Quanta (Notebook PC)	Dell, Gateway, Apple, Siemens, IBM, HP
Arima (Notebook PC)	Compaq
FIC (Notebook PC)	NEC Japan
Twin-Head (Notebook PC)	NEC, HP, Sharp, Winbook
Compal (Notebook PC)	Fujitz, HP, Dell, Toshiba
GVC (Notebook PC)	PBNEC
Acer (Notebook PC)	Acer/TI, IBM, Apple
Alpha-Top (Notebook PC)	Apple, PBNEC
Clevo (Notebook PC)	Hitachi, Epson

Source: 1. C. Wang, "The Information Technology Industry @ Taiwan", The Financial Information, Taipei, Taiwan, 1999.
 2. "Taiwan Notebook PC is the World No. 1", Global Views Monthly 162, Taipei, Taiwan, December, 1999.

Figure 13

Taiwan's Wireless Phone Industry

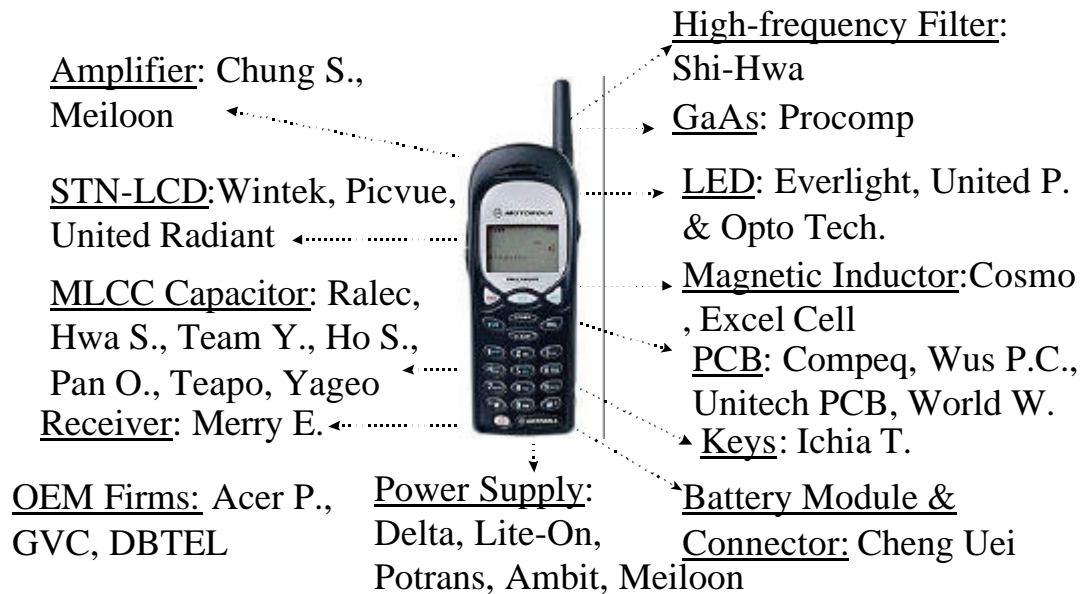

Source: Wan-Pou Investment Co., Taiwan. Note: All companies are public.

Taiwan's Mobile Phone OEM Customers, 2000

Customer	Product	Taiwanese OEM Partner
Motorola	Mobile Phone	DBTEL Inc. (cordless phone); Acer Peripheral
	IC Mfg.	TSMC; UMC
	PCB	Wus Printed Circuit Co; United PCB Co. Zio-De;
	LED	I-Kwon
	Voltage Converter	Fe-Hon
	Power Supply	Lite-On (power supply, LED)
Ericsson	Panel	Picvue Elec. (LCD/CRT)
	PCB	Compeq
	Receiver	Mei-Lui
Alcatel	Panel	Compeq (PCB)
	Mobile Phone	GVC (Desktop PC, Motherboard)
Qualcomm	Panel	Compeq (PCB)
	PCB	Wus Printed Circuit Co.
	Panel	Compeq (PCB)

Source: Telecommunication Network, Special Edition, Taiwan, 2000

Figure 14. Profitability of IT Manufacturers, Taiwan and US, 1995-1998

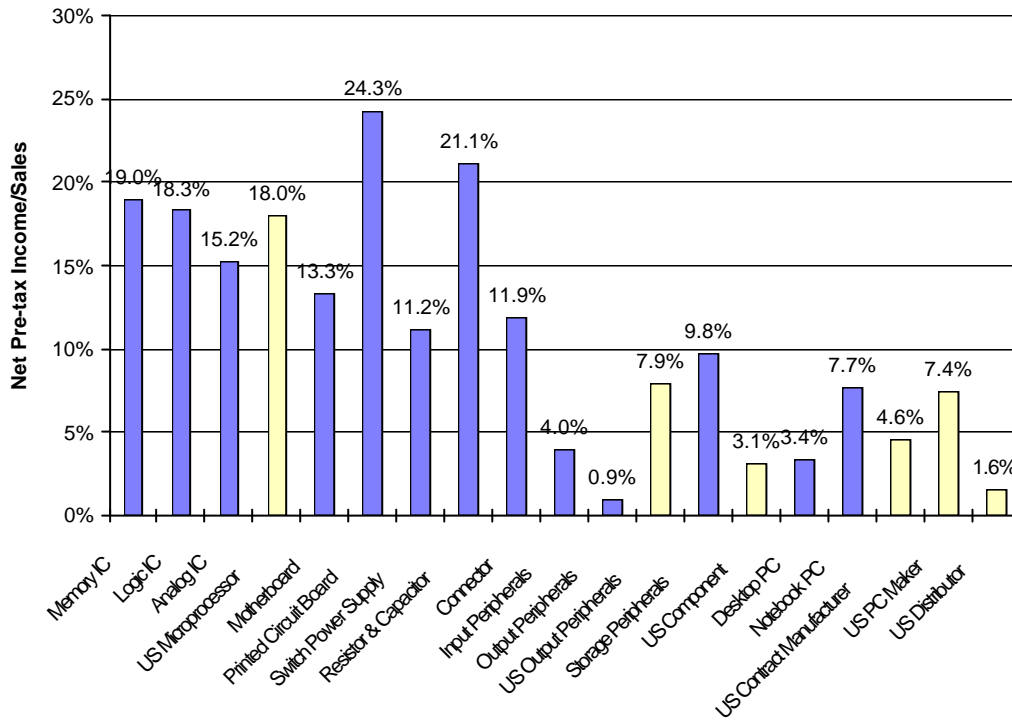

Source: 1. "The Largest Corporations in Taiwan 1998", China Credit Information Service, LTD., 1998. Also, 1997, 1996 and 1995 editions.
 2. Company Research Profile by ETRADE.

Figure 15. Overseas Production of Taiwan's IT Industry, 1998

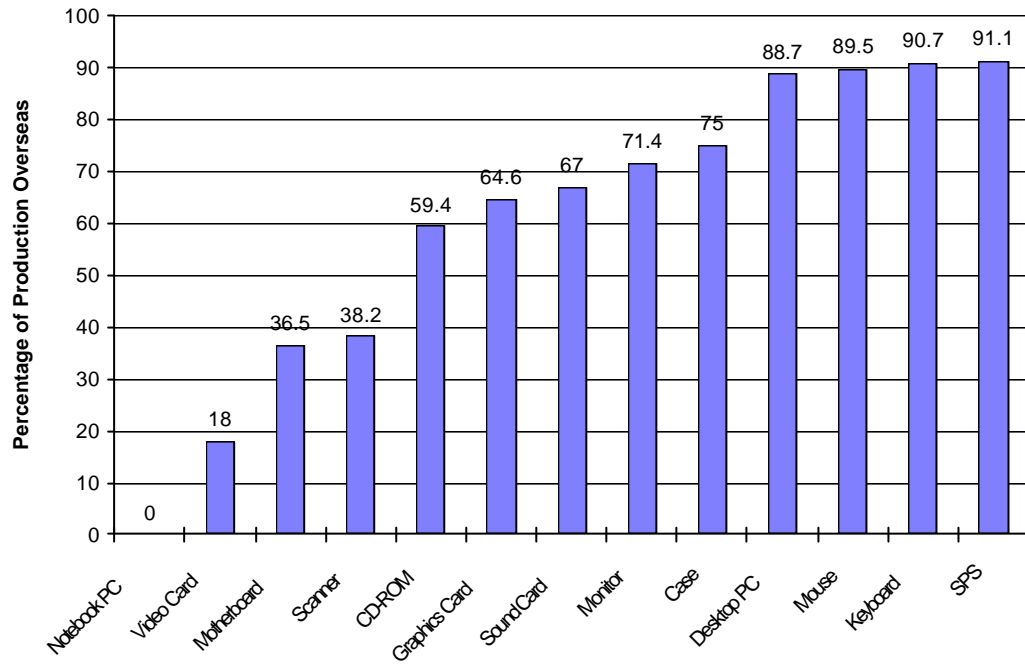

Note: The majority (90%) of Taiwan's overseas production is in Mainland China
Source: MIC ITIS Plan, 12/98

Figure 15: Taiwan IT Investment in China, Officially Permitted: 1991-2000

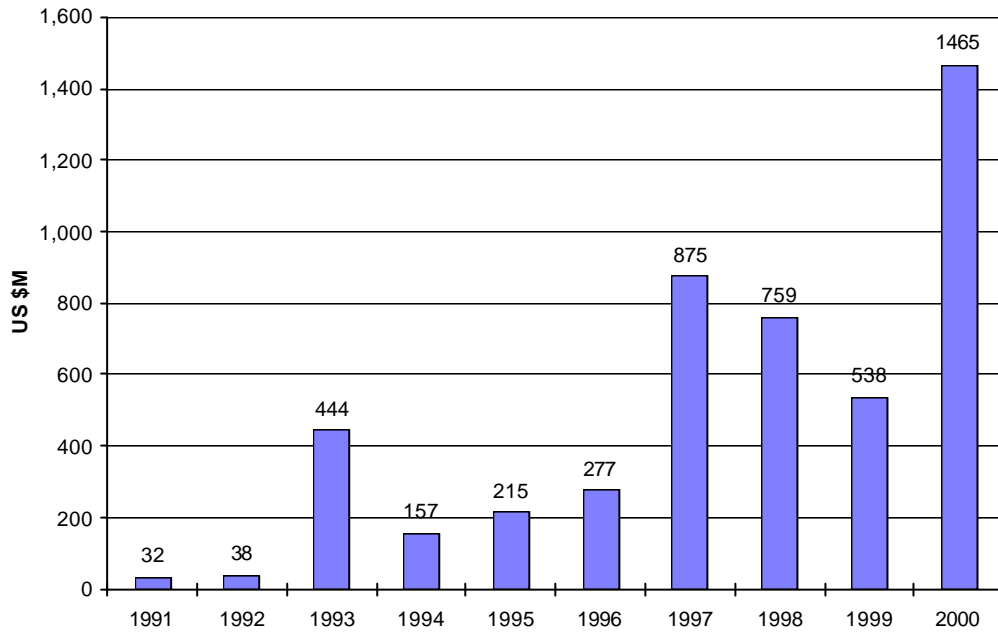
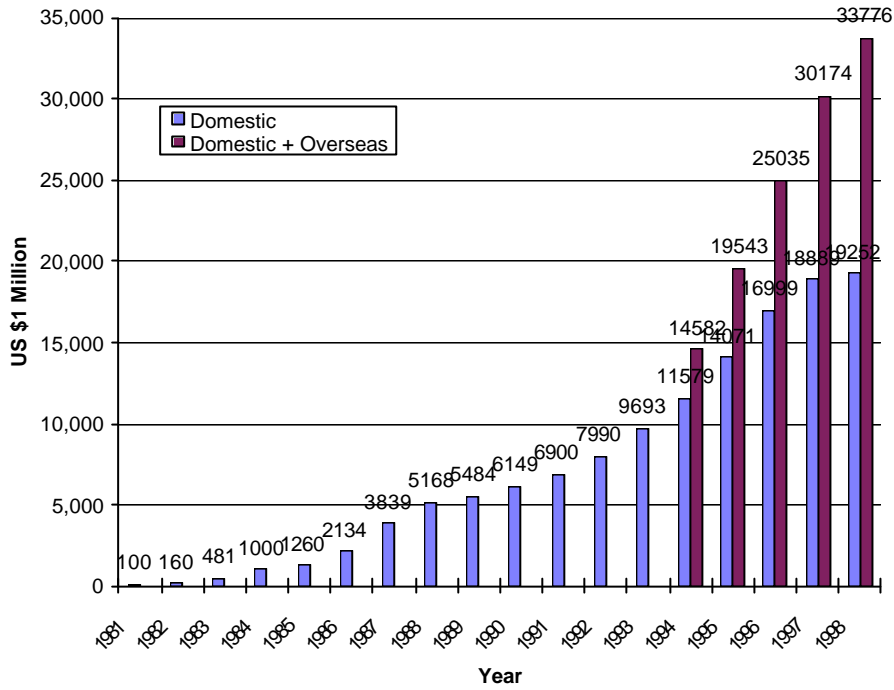

Figure 17. Annual Value of IT Production, Taiwan, 1981-1998



Source: 1. C. Huang, "R.O.C.: Republic of computers", The Common Wealth, Taipei, Taiwan, 1995.

2. <http://mic.iii.org.tw/english/asiait/issues/special/1998/98sp1.htm>

Appendix A. Profitability of IT Manufacturers, US and Taiwan, 1995-1999

Company	1995	1996	1997	1998	1999
Memory IC					
Mosel	30.96	32.59	5.99	-25.88	15.98
Winbond	25.52	18.64	20.51	-13.2	12.04
UMC	43.72	31.8	39.29	21.45	36.11
TSMC	44.37	48.15	35.31	27.17	32.96
Holtek	19.57	15.68	19.16	-34.26	5.97
Macronix	21.86	31.88	10.59	-15.75	3.53
Logic IC					
Silicon I.S.	22.48	11.89	7.76	16.53	16.58
Via		15.94	30.18	23.29	18.49
Acer Lab		1.5	1.57	1.22	7.33
UMC	43.72	31.8	39.29	21.45	36.11
Analog IC					
Mison T.	5.74	9.91	24.05	21.19	16.18
US Microprocessor					
Intel	34.8	38.06	42.52	34.78	38.21
AMD	15.56	-10.65	-3.23	-7.67	2.74
Motherboard					
Universal S.	6.51	7.48	9.07	1.69	N/A
Micro-star		9.8	10.52	7.01	9.82
Asustek	22.69	30.52	34.41	32.54	29.96
Giga-byte T.	0.64	7.82	12.17	11.34	10.68
Printed Circuit Board					
Compeq	19.25	23.46	29.7	24.8	10.95
Switch Power Supply					
Delta	7.96	0.41	21.13	20.95	19.68
Ambit M.		10.3	10.39	8.35	8.34
Resistor & Capacitor					
Yageo	26.27	42.7	78.41	53.36	50.48
Luxon	12.98	11.93	15.49	16.13	N/A
Teapo	-0.32	2.81	9.73	7.97	-5.33
Pan Overs.		15.38	15.6	14.2	16.97
Connector					
Hon Hai P.	10.51	15.22	17.1	16.8	16.06
Cheng Uei			10.31	7.63	N/A
US Component					
Seagate	9.01	3.85	9.97	-10.31	27.54
Input Peripherals					
UMAX	14.51	9.67	5.04	-10.72	-24.23
Mustek	4.83	11.64	7.32	-11.97	-22.55
Microtek		16.89	15.58	-13.56	-45.67
Kye	-3.64	8.45	9	-0.54	-11.32
Chicony	0.6	0.5	4.35	5.18	-5.59
Output Peripherals					
ADI	4.69		5.44	-2.32	-12.03
Acer P.	7.17	4.81	6.48	4.42	5.65
Chuntex	2.08	0.96	4.42	-24.7	-49.45
Mag T.	3.96	1.85	1.91	-8.97	-13.97

Appendix A continued

US Output Peripherals

Lexmark	2.93	8.49	10.22	12.08	13.3
---------	------	------	-------	-------	------

Canon (Jap.)	5.41	7.15	8.5	8.48	N/A
--------------	------	------	-----	------	-----

Storage Peripherals

Ritek	14.26	15.39	19.36	29.38	41.55
-------	-------	-------	-------	-------	-------

Prodisc T.		5.47	15.62	15.57	29.51
------------	--	------	-------	-------	-------

Lite-On	2.33	4.63	5.11	11.45	4.22
---------	------	------	------	-------	------

Pan Inter.	8	3.5	9.67	-16.02	-4.89
------------	---	-----	------	--------	-------

Desktop PC

Mitac	2.44	7.45	1.69	5.45	6.76
-------	------	------	------	------	------

FIC	3.14	5.74	6.21	0.09	0.08
-----	------	------	------	------	------

GVC	6.51	3.13	3	-4.44	-33.2
-----	------	------	---	-------	-------

Notebook PC

Quanta	5.72	6.19	17.07	18.26	12.47
--------	------	------	-------	-------	-------

Inventec	13.29	8.04	12.09	9.16	5.86
----------	-------	------	-------	------	------

Compal	3.29	10.24	13.54	13.8	11.92
--------	------	-------	-------	------	-------

Arima		-4.35	8.28	9.5	7.4
-------	--	-------	------	-----	-----

Twinhead	-8.14	2.99	4.22	6.22	-5.23
----------	-------	------	------	------	-------

US Contract Manufacturer

SCI	2.83	2.99	3.28	3.47	3.23
-----	------	------	------	------	------

Solectron	5.81	6.14	6.44	5.65	5.15
-----------	------	------	------	------	------

US PC Maker

Dell	6.13	7.23	9.63	11.1	11.42
------	------	------	------	------	-------

Gateway	7.13	7.61	3.24	7.24	N/A
---------	------	------	------	------	-----

US Distributor

Bestbuy	1.85	1.09	0.03	1.84	3.62
---------	------	------	------	------	------

Ingram Micro	1.57	1.64	1.97	1.85	1.03
--------------	------	------	------	------	------

Note: Average Annual Net Pre-tax Profit/Sales, %, 1995-1999